

INSTRUCTION MANUAL

PRELIMINARY

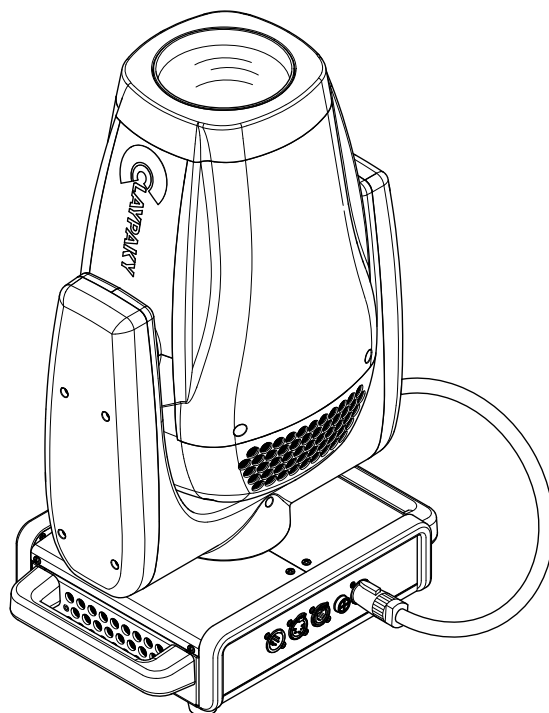

INDEX

Page	Contents
2	1. Safety information
3	2. Unpacking and preparation
4	3. Installation and start-up
4	3.1 Installing the fixture
5	3.2 Connecting to manis supply
5	3.3 Connecting the control signal line: DMX / Art-Net
6	3.4 Switching on the fixture and basic SetUp
8	4. Maintenance
8	4.1 Opening the covers
9	4.2 Periodical cleaning
10	4.3 Effects module removal
14	4.4 Rotating gobos
15	4.5 Battery removal
16	5. Dimensions
16	6. Cause and solution of problems

*Congratulations on choosing a Claypaky product!
We thank you for your custom.*

Please note that this product, as all the others in the rich Claypaky range, has been designed and made with total quality to ensure excellent performance and best meet your expectations and requirements.

1. SAFETY INFORMATION

EN

SAFETY INFORMATION

IMPORTANT: Claypaky recommends you carefully read and keep the safety information on this product, also available in digital format at the following link:

www.claypaky.com

Ref: FIS025 - Safety Information Arolla Spot/Profile MP

IT

INFORMAZIONI DI SICUREZZA

IMPORTANTE: Claypaky raccomanda di leggere accuratamente e conservare le informazioni di sicurezza relative a questo prodotto, sempre reperibili in versione digitale al seguente link:

www.claypaky.com

Rif: FIS025 - Safety Information Arolla Spot/Profile MP

DE

INFORMATIONEN ZUR SICHERHEIT

WICHTIG: Claypaky empfiehlt, die Sicherheitsinformationen bezüglich dieses Produkts genau zu lesen und aufzubewahren. Sie sind in Digitalversion immer unter folgendem Link auffindbar:

www.claypaky.com

Ref: FIS025 - Safety Information Arolla Spot/Profile MP

ES

INFORMACIONES DE SEGURIDAD

IMPORTANTE: Claypaky recomienda leer detenidamente y conservar la información de seguridad relativa a este producto. Además, está disponible una versión digital de la misma en el siguiente enlace:

www.claypaky.com

Ref: FIS025 - Safety Information Arolla Spot/Profile MP

FR

CONSIGNES DE SÉCURITÉ

IMPORTANT: Claypaky recommande de lire attentivement et de conserver les informations de sécurité relatives à ce produit, disponibles en version digitale au lien suivant:

www.claypaky.com

Réf. : FIS025 - Safety Information Arolla Spot/Profile MP

RU

ИНСТРУКЦИЮ ПО ТЕХНИКЕ БЕЗОПАСНОСТИ

ВАЖНО: Claypaky рекомендует внимательно прочитать и сохранить инструкцию по технике безопасности данного изделия, которая всегда доступна в электронном формате по следующей ссылке:

www.claypaky.com

Наименование: FIS025 - Safety Information Arolla Spot/Profile MP

2. UNPACKING AND PREPARATION

1



Packing contents - Fig. 1

2

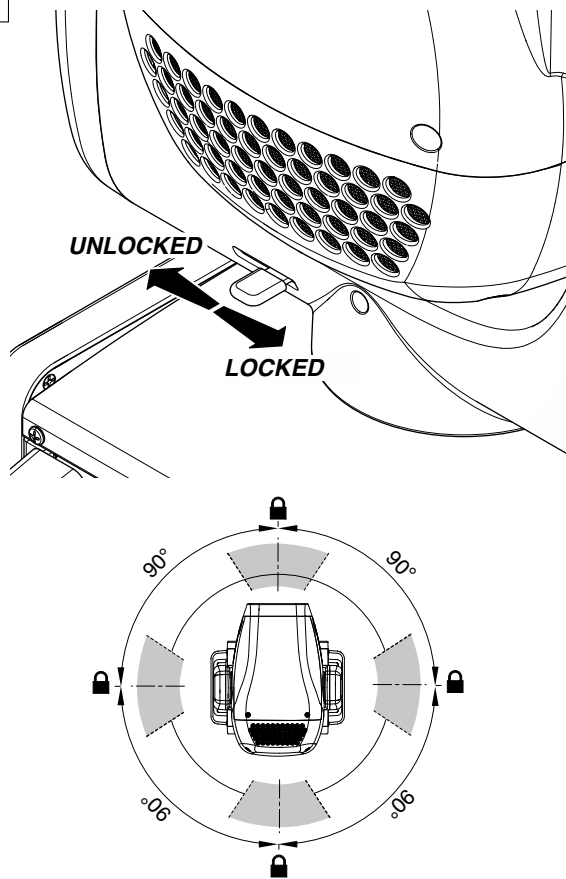

PAN Mechanism Lock and Release (every 90°) - Fig. 2

3

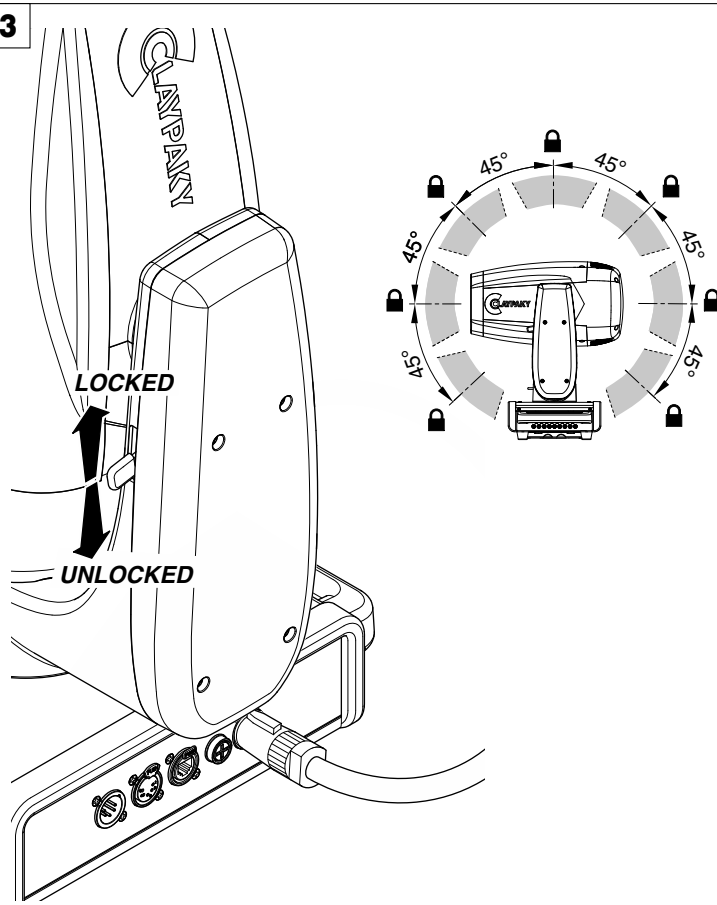

TILT Mechanism Lock and Release (every 45°) - Fig. 3

3. INSTALLATION AND START-UP

3.1 Installing the fixture

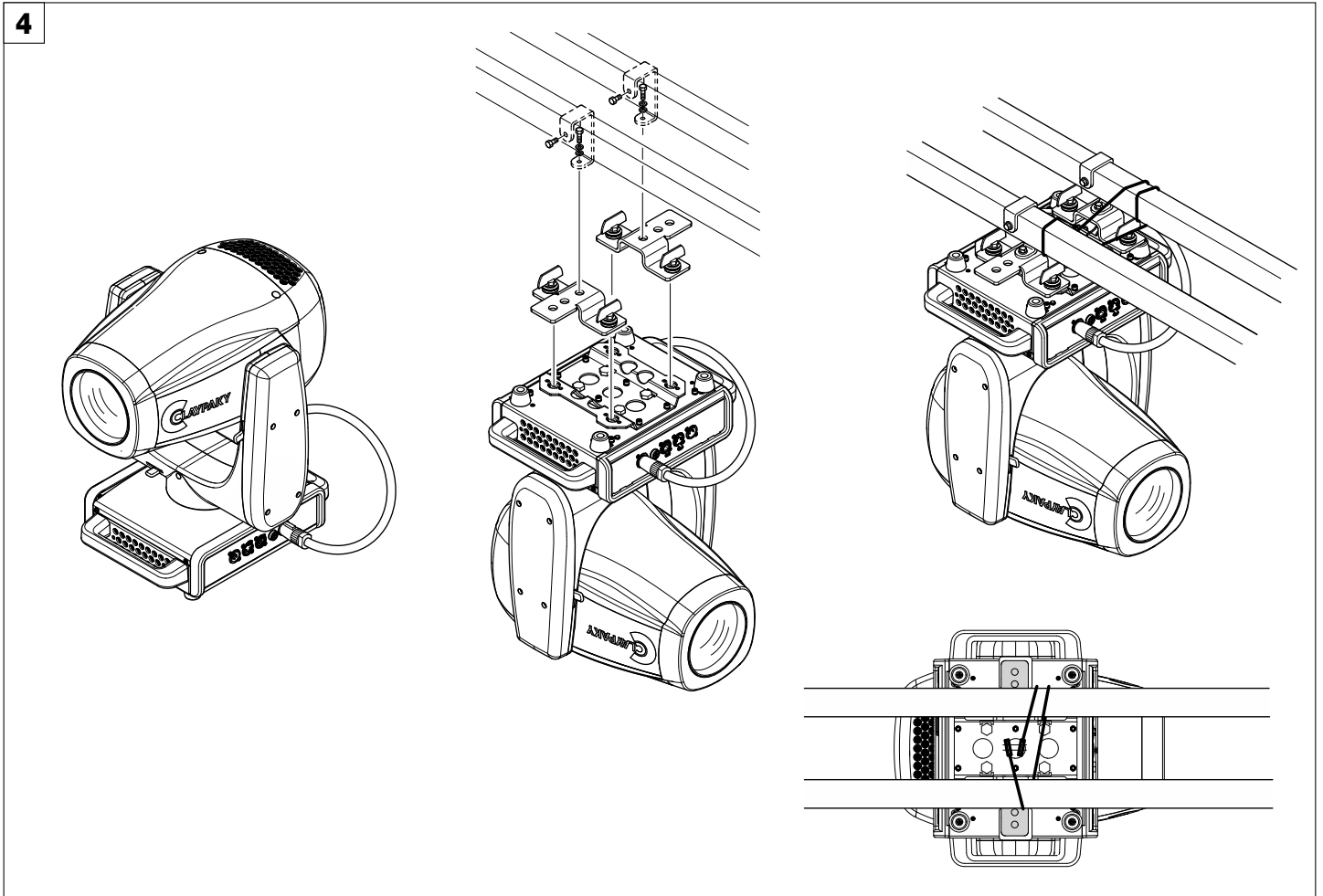

Installing the projector - Fig. 4

The projector can be installed on the floor resting on special rubber feet, on a truss or on the ceiling or wall.

WARNING: with the exception of when the projector is positioned on the floor, the safety cable must be fitted. (Cod. 105041/003 available on request). This must be securely fixed to the support structure of the projector and then connected to the fixing point at the centre of the base.

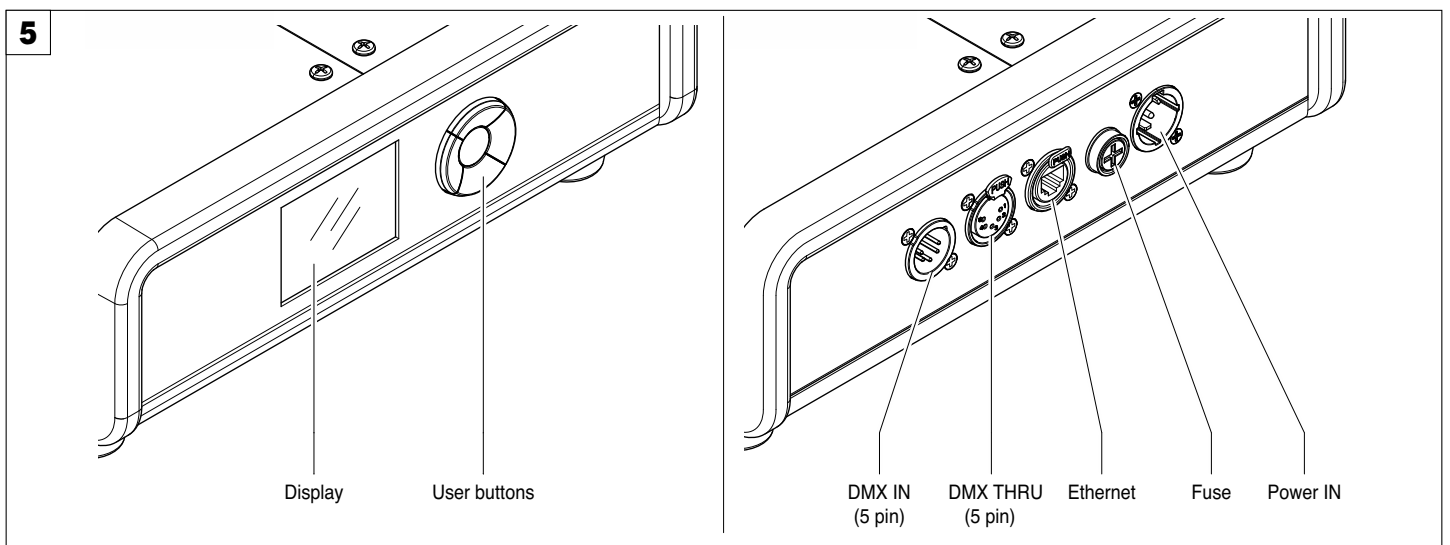

Control panel - Fig. 5

3.2 Connecting to mains supply

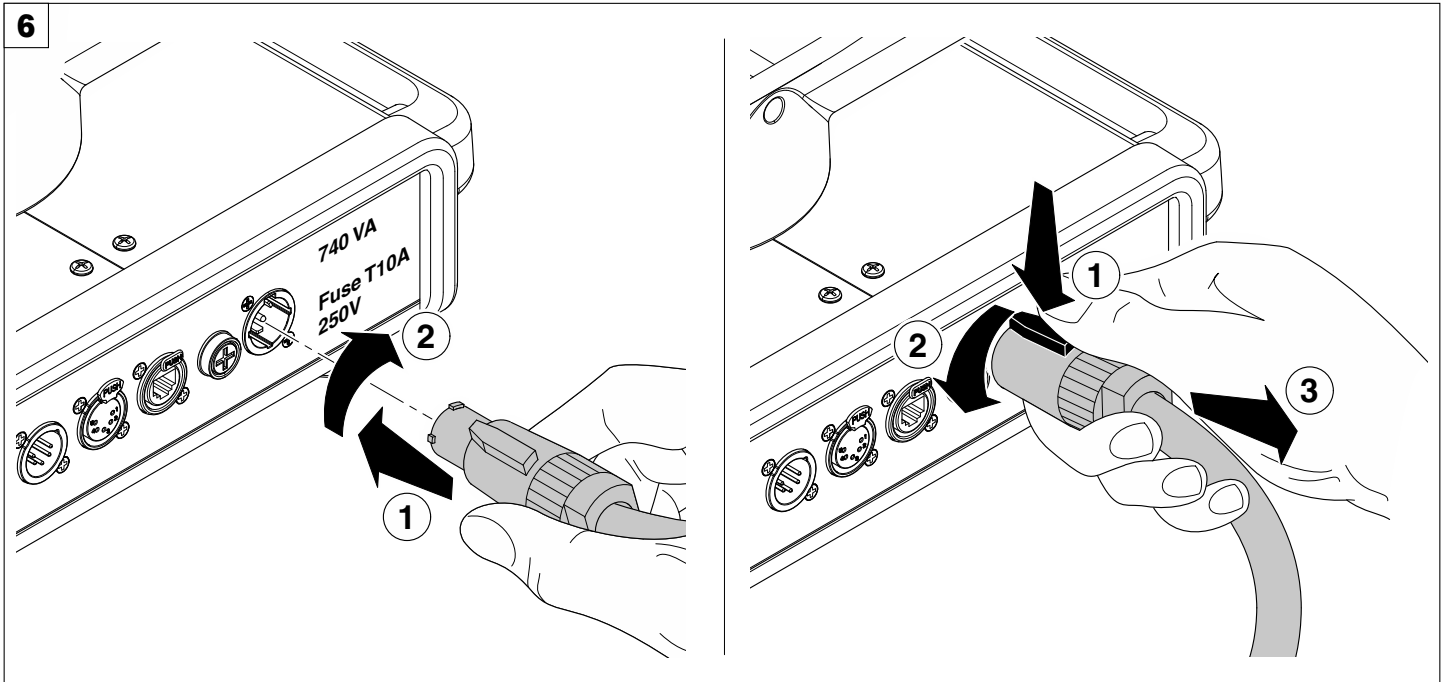

Connecting and disconnecting power cable - Fig. 6

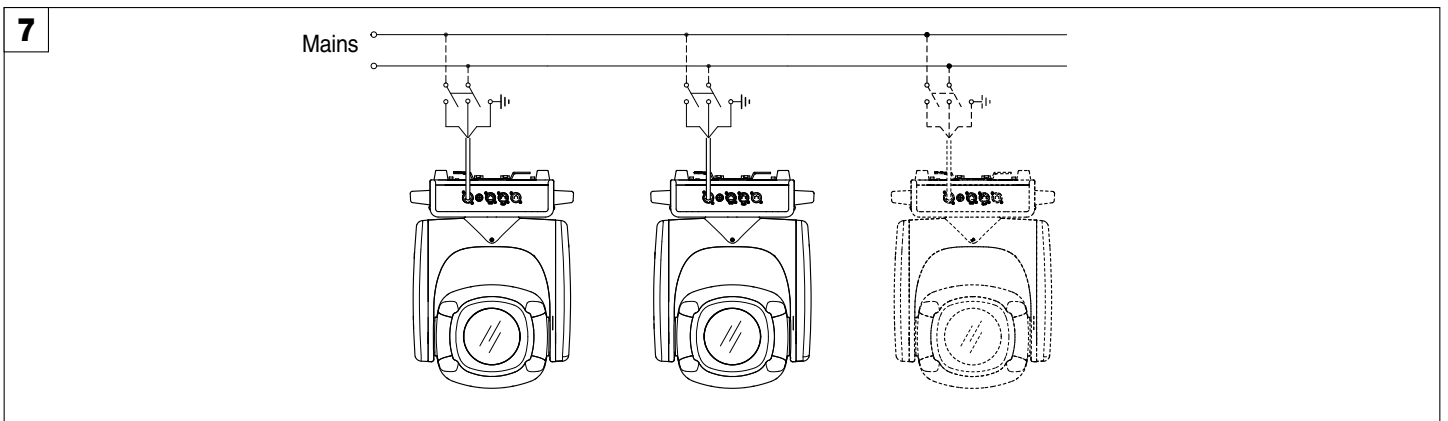

Connecting to the mains supply - Fig. 7

3.3 Connecting the control signal line: DMX / Art-Net

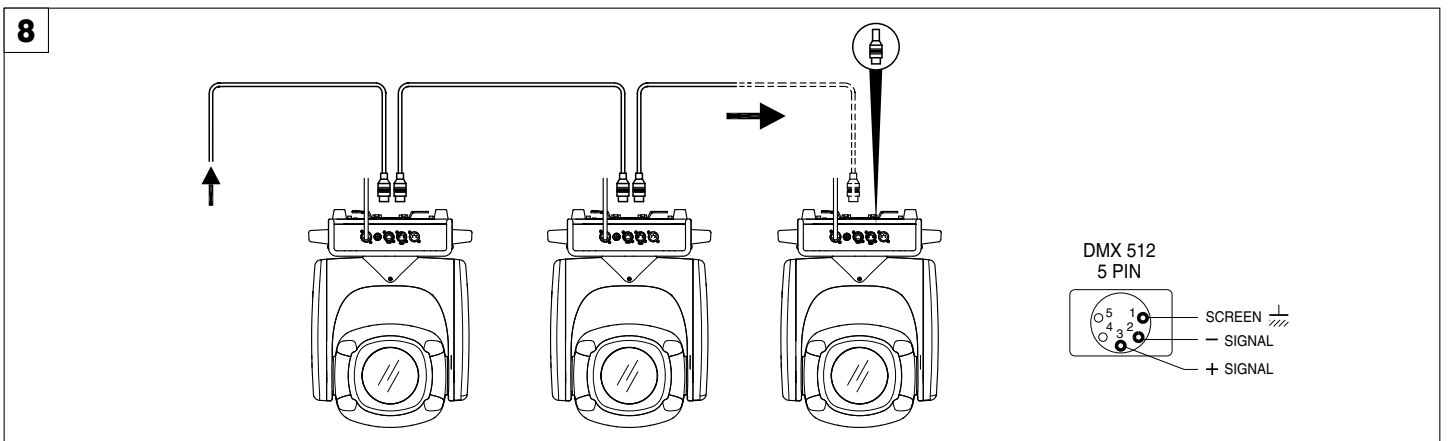

Connecting to the control signal line (DMX) - Fig. 8

Use a cable conforming to specifications EIA RS-485: 2-pole twisted, shielded, 120Ohm characteristic impedance, 22-24 AWG, low capacity. Do not use microphone cable or other cable with characteristics differing from those specified. The end connections must be made using XLR type 5 pin male/female connectors. A terminating plug must be inserted into the last projector with a resistance of 120Ohm (minimum 1/4 W) between terminals 2 and 3.

IMPORTANT: The wires must not make contact with each other or with the metal casing of the connectors. The casing itself must be connected to the shield braid and to pin 1 of the connectors.

3.4 Switching on the fixture and basic SetUp

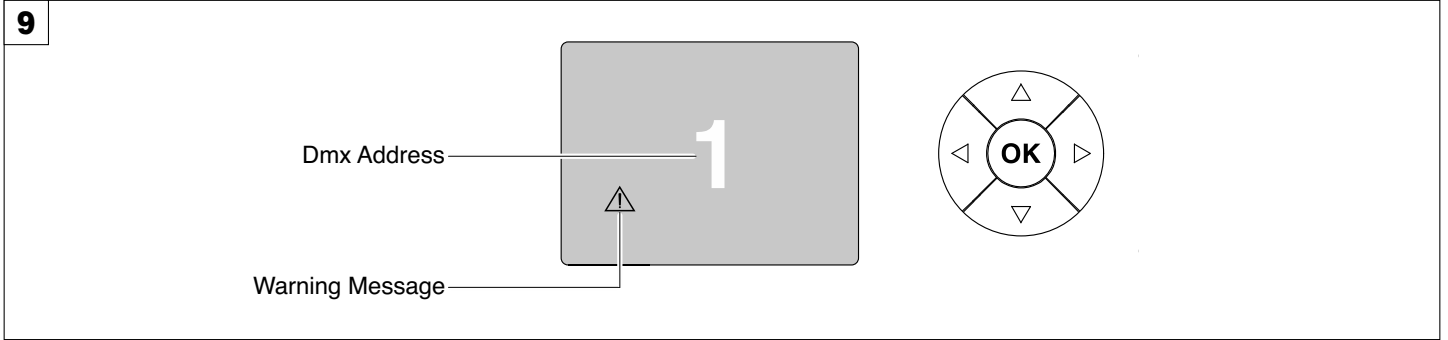

Switching on the projector - Fig. 9

Switch-on the fixture. The projector starts resetting the effects. At the same time, the following information scrolls on the display:

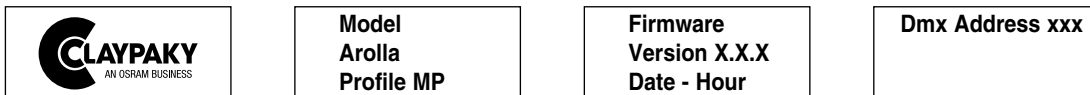

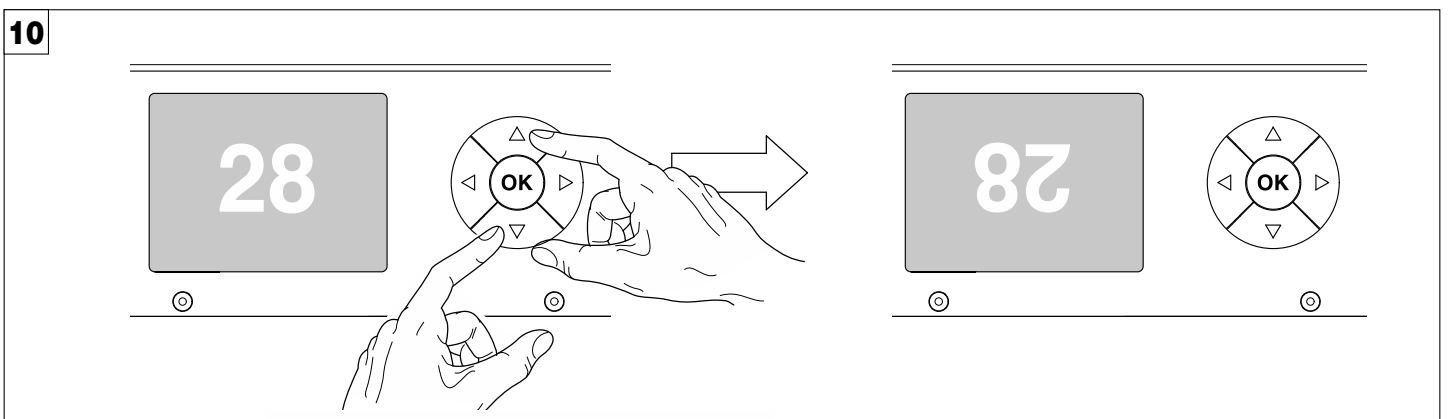

On conclusion of resetting in case of absence of the dmx signal, Pan and Tilt move to the “Home” position (Pan 128 bit - Tilt 128 bit). The control panel (Fig. 8) has a display and buttons for the complete programming and management of the projector menu. The display can be in one of two conditions: rest status and setting status. When it is in the rest status, the display shows the projector’s DMX address.

During menu setting status, after a wait time (about 30 seconds) without any key having been pressed, the display automatically returns to rest status. It should be noted that when this condition occurs, any possible value that has been modified but not yet confirmed with the **OK** key will be cancelled.



Reversal of the display - Fig. 10

To activate this function, press UP  and DOWN  keys simultaneously while the display is in the rest mode. This status will be memorised and maintained even for the next time it will be switched on. To return to the initial state, repeat the operation all over again.

Setting the projector starting address

On each projector, the starting address must be set for the control signal (addresses from 1 to 512).

The address can also be set with the projector switched off.

Functions of the buttons - Using the menu

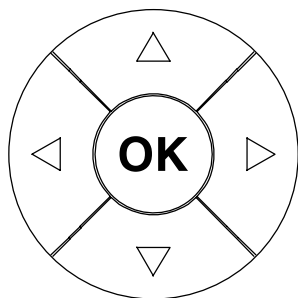

Confirms the displayed value, or activates the displayed function, or enters the successive menu.



DOWN

Decreases the value displayed (with auto-repetitions) or passes to the next item in the menu.



UP

Increases the value displayed (with auto-repetitions) or passes to the previous item in a menu.



LEFT







Return to the top level



RIGHT

Enters the successive menu.

USING THE MENU:

- 1) Press LEFT  once – “Main Menu” appears on the display.
- 2) Use the UP  and DOWN  keys to select the menu to be used:
 - Setup (Setup Menu): To set the setting options.
 - Option (Option Menu): To set the operating options
 - Informations (Informations Menu): To read the counters, software version and other information.
 - Manual Control (Manual control Menu): To trigger the test and manual control functions.
 - Test (Test Menu): To check the proper functioning of effects
 - Advanced (Advanced Menu): Access to the "Advanced menu" is recommended for a trained technical personnel.
- 3) Press  to display the first item in the selected menu.
- 4) Use the UP  and DOWN  keys to select the MENU items.

Setting addresses and options with the projector disconnected

The projector's DMX address, as well as other possible operating options, can also be set when the appliance is disconnected from the electricity supply. All that is needed is to press RIGHT  to momentarily activate the display and thus access the settings. Once the required operations have been carried out, the display will switch off again after a wait time of 30 seconds.

4. MAINTENANCE

4.1 Opening the covers

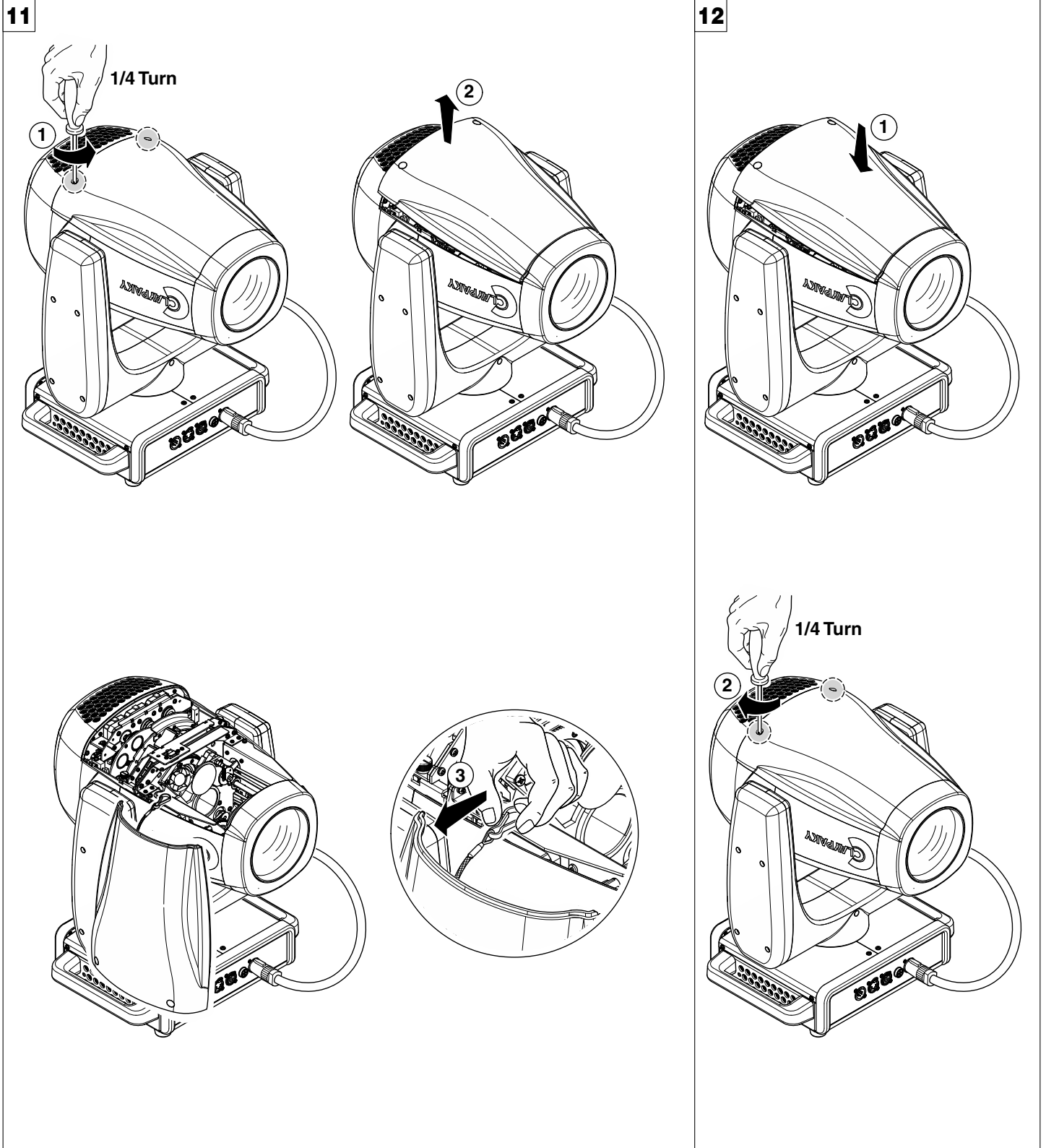

Locking and releasing Pan and Tilt movements - Refer to the instructions in the UNPACKING AND PREPARATION section.
Opening the head covers - Fig. 11.

Closing the head covers - Fig. 12.

4.2 Periodical cleaning

13

NOTE: keep a careful cleaning of the "CMY/colour filters assembly" to prevent rapid deterioration.



Light collimation system

This product contains internal light collimation system. Avoid intense light from any angle.

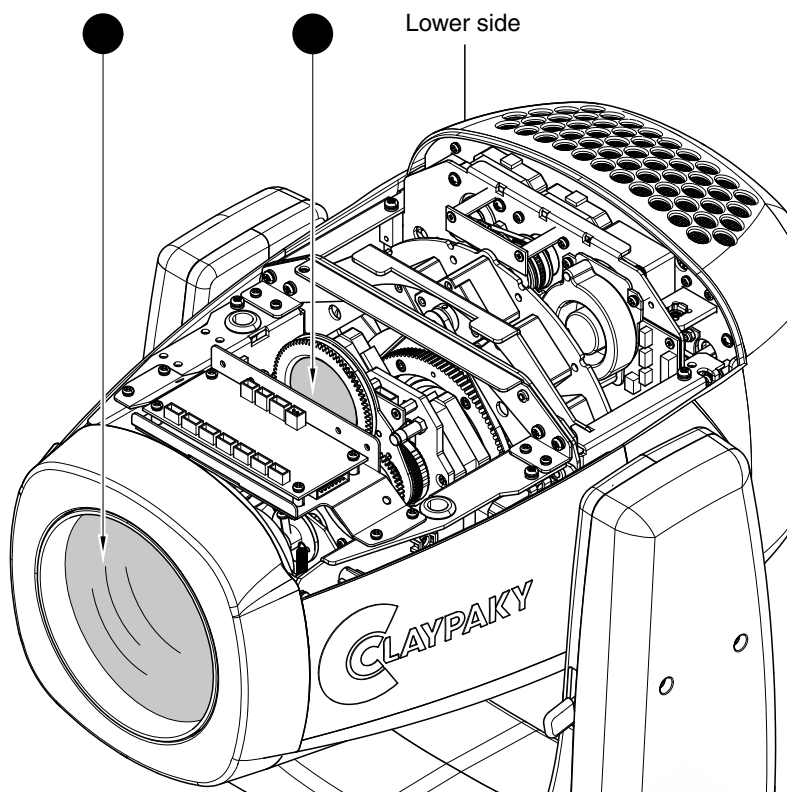
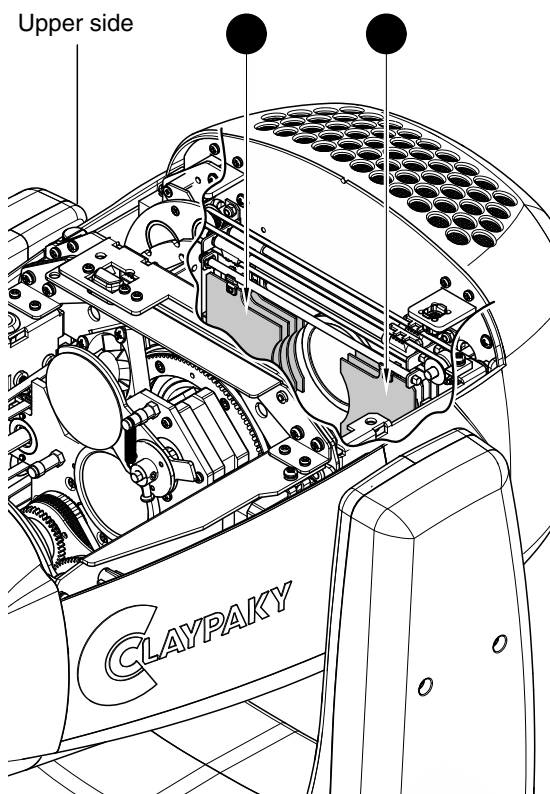
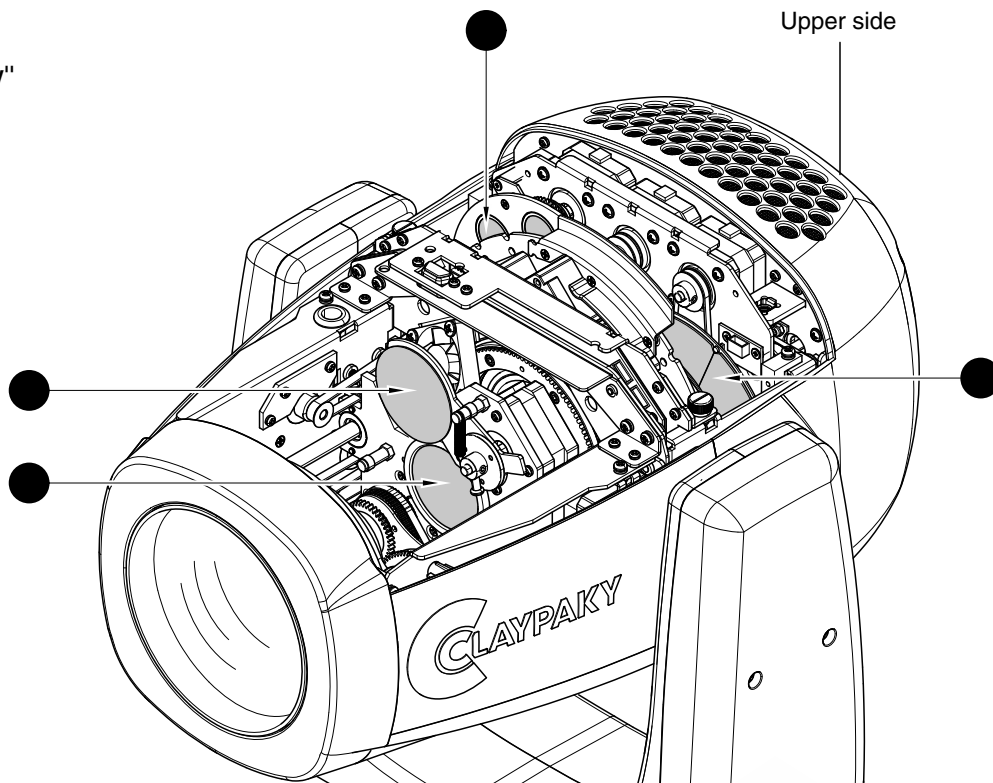

Periodical cleaning - Fig. 13

To ensure optimal operation and performance for a long time it is essential to periodically clean the parts subject to dust and grease deposits. The frequency with which the following operations are to be carried out depends on various factors, such as the amount of the effects and the quality of the working environment (air humidity, presence of dust, salinity, etc.).

Use a soft cloth dampened with any detergent liquid for cleaning glass to remove the dirt from the reflectors, from the lenses and filters. It is recommended that the projector undergoes an annual service by a qualified technician for special maintenance involving at least the following operations:

- General cleaning of internal parts.
- Restoring lubrication of all parts subject to friction, using lubricants specifically supplied by Claypaky.
- General visual check of the internal components, cabling, mechanical parts, etc.
- Electrical, photometric and functional checks; eventual repairs.

4.3 Effects module removal

14

Upper side

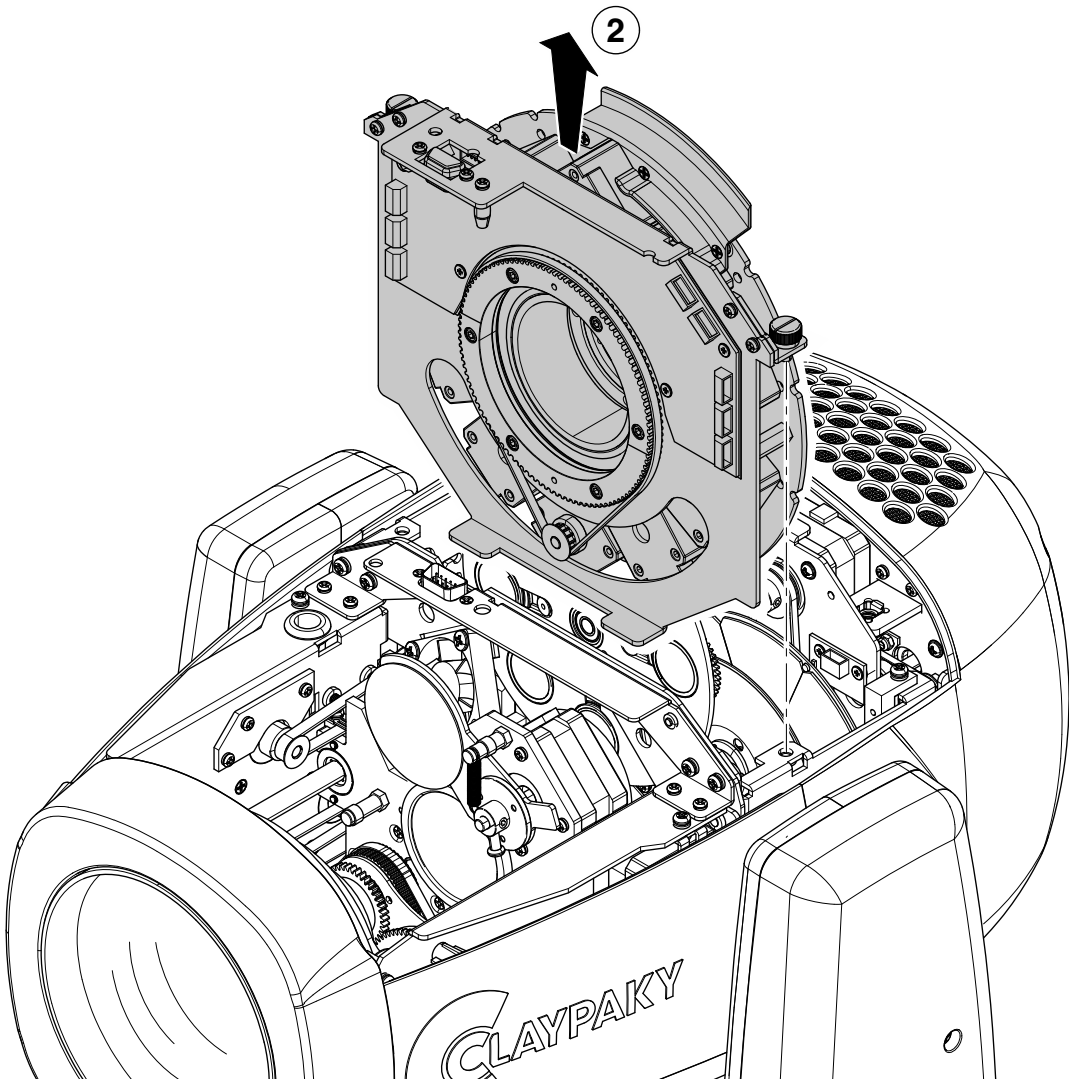
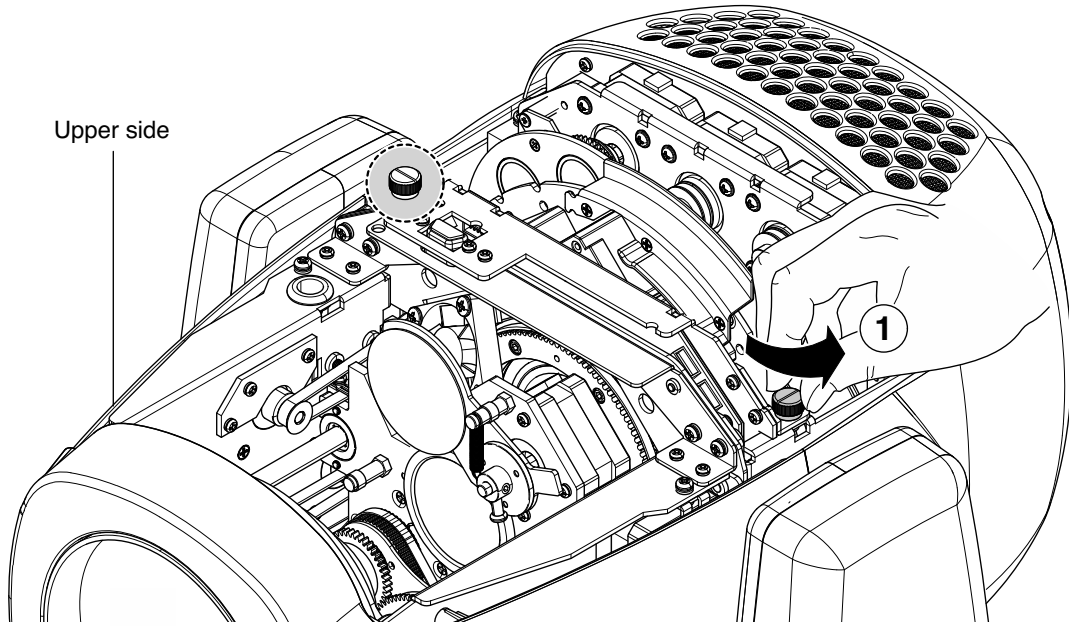

Extraction of the effect modules - Fig. 14.

IMPORTANT: Grasp the modules using the support structure and not the details which could get damaged.

Insertion of the effect modules: Repeat the operations indicated in Fig. 14, 15 and 16 in reverse order.

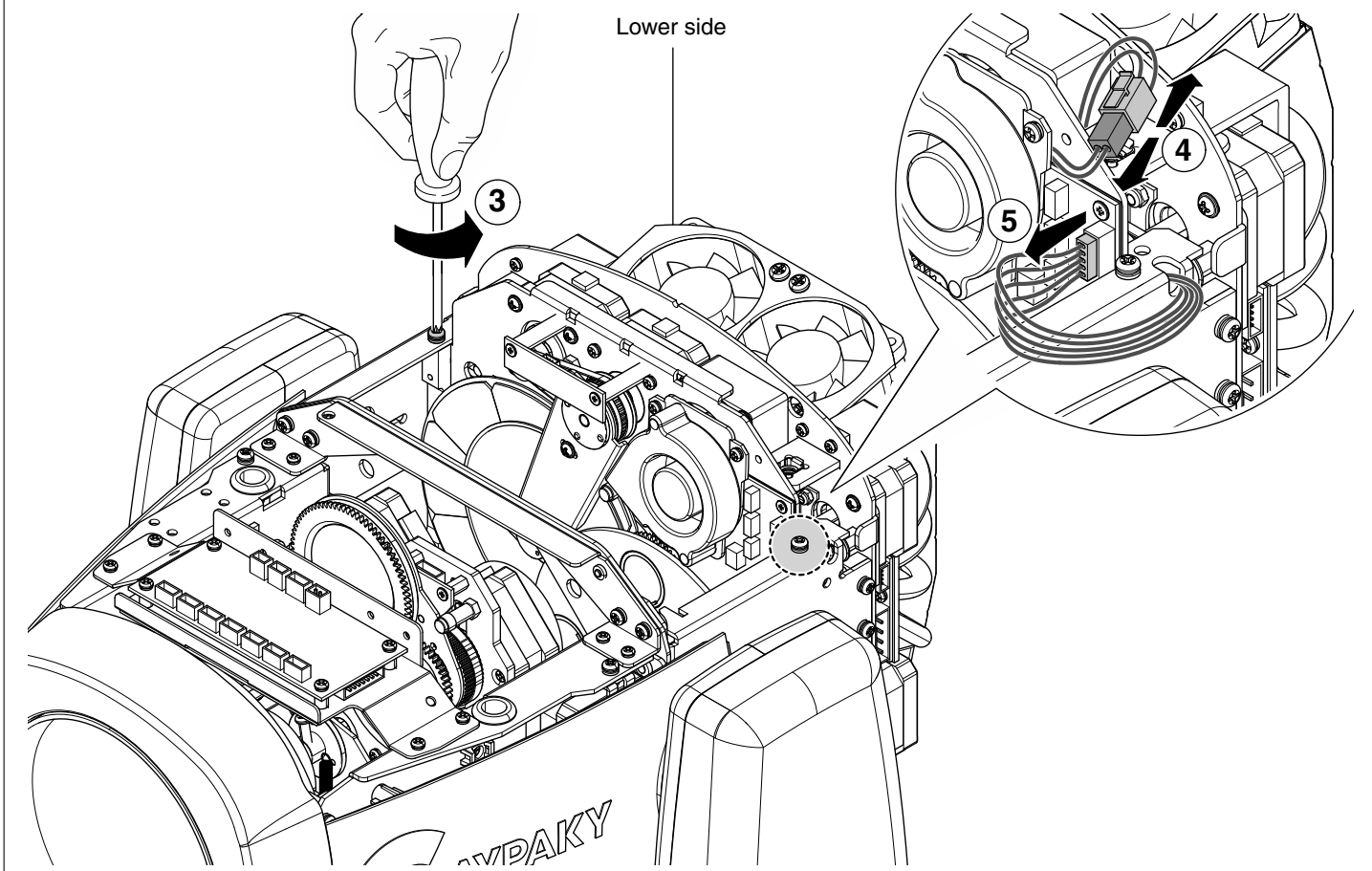
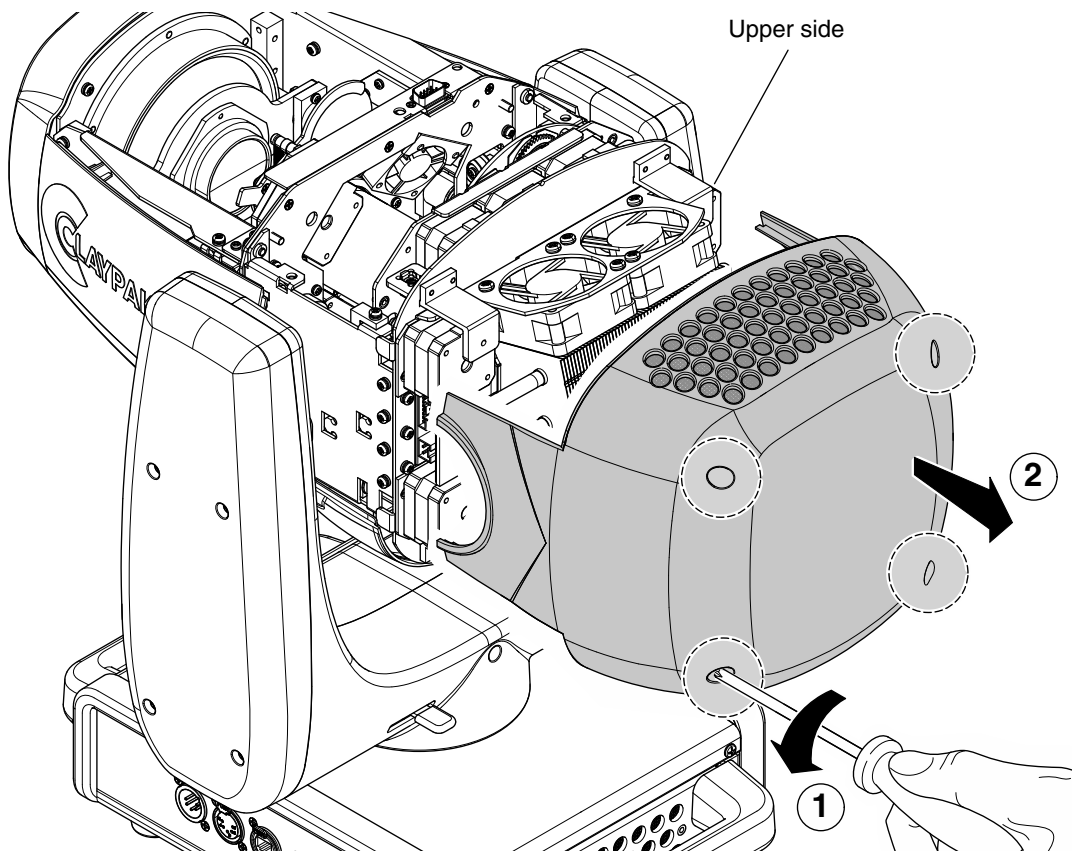

Extraction of the effect modules - Fig. 15.

IMPORTANT: Grasp the modules using the support structure and not the details which could get damaged.

Insertion of the effect modules: Repeat the operations indicated in Fig. 14, 15 and 16 in reverse order.

Upper side

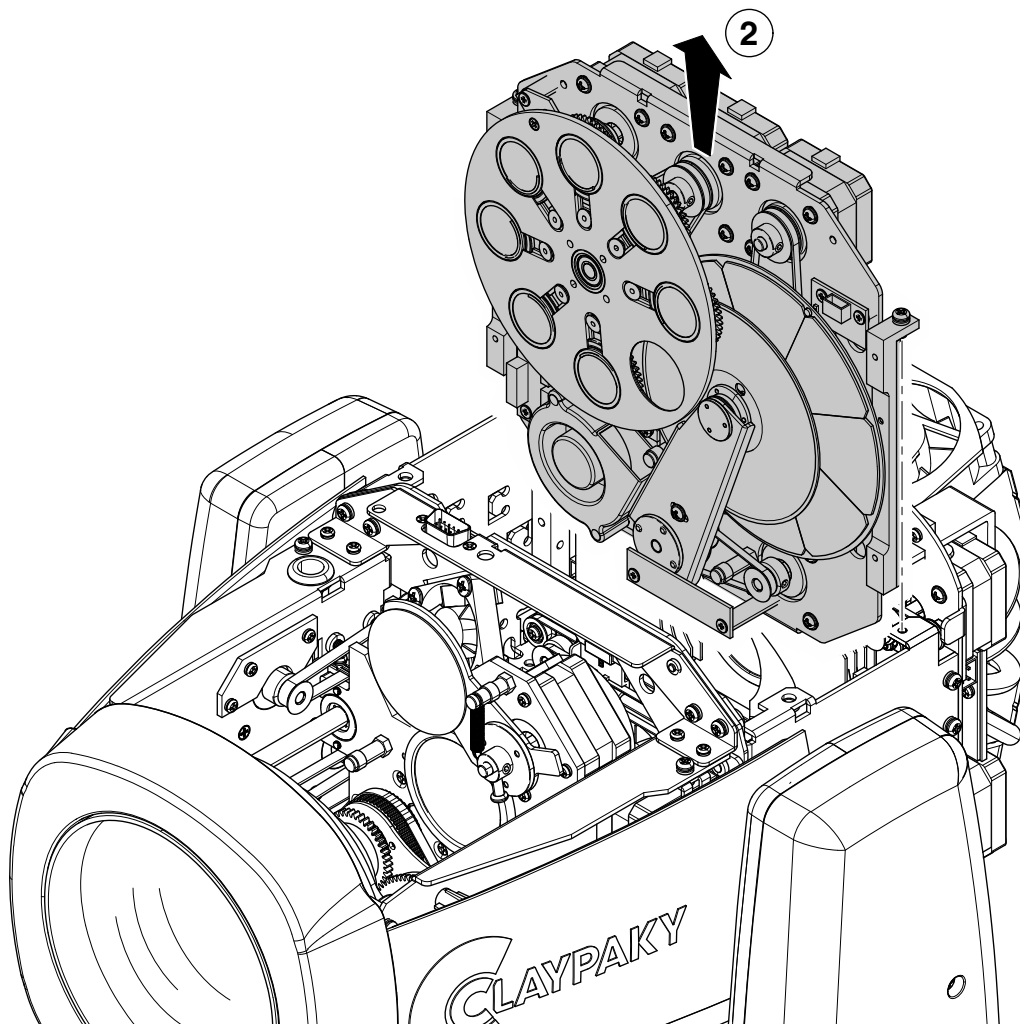
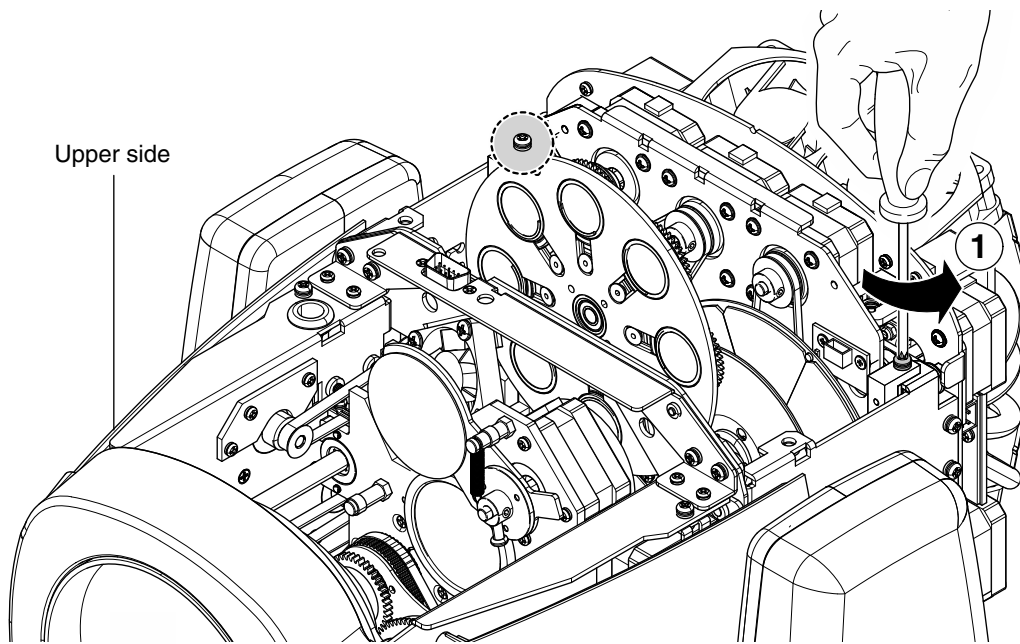

Extraction of the effect modules - Fig. 16.

IMPORTANT: Grasp the modules using the support structure and not the details which could get damaged.

Insertion of the effect modules: Repeat the operations indicated in Fig. 14, 15 and 16 in reverse order.

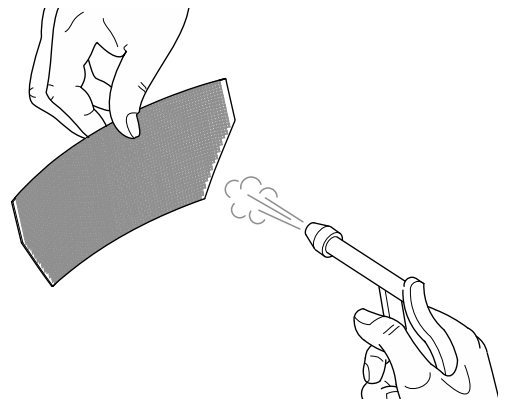
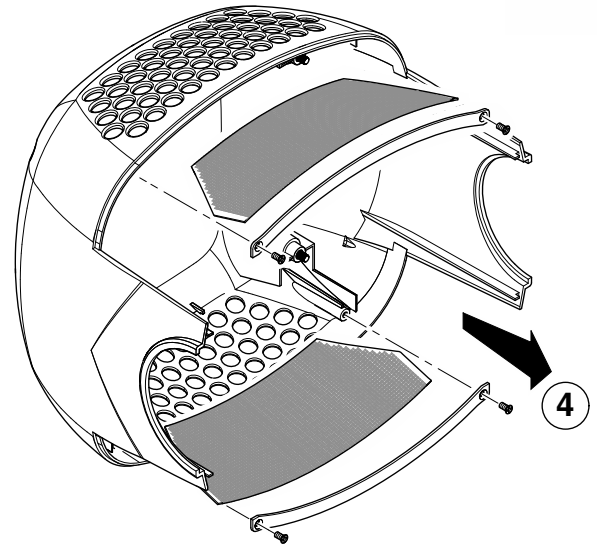
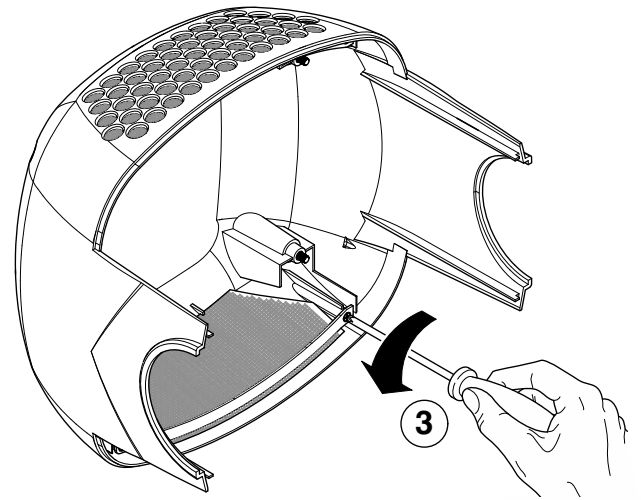
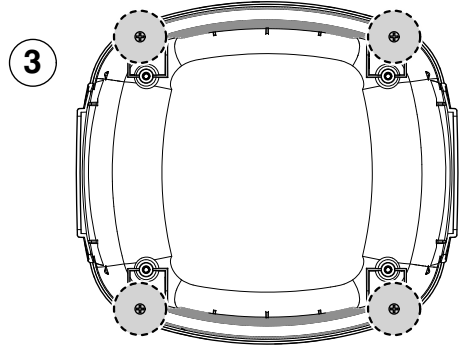
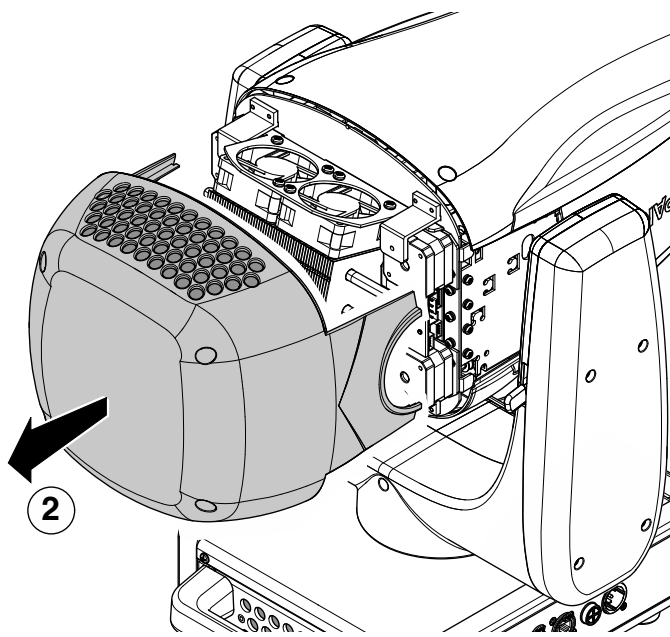
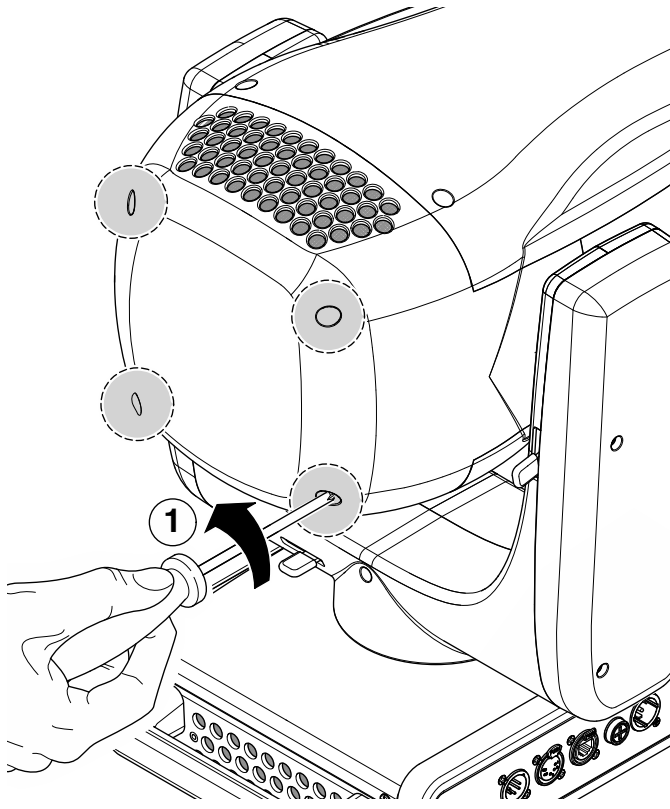
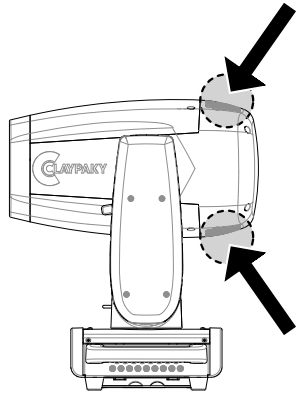

Cleaning of the grids - Fig. 17.

4.4 - Rotating gobos

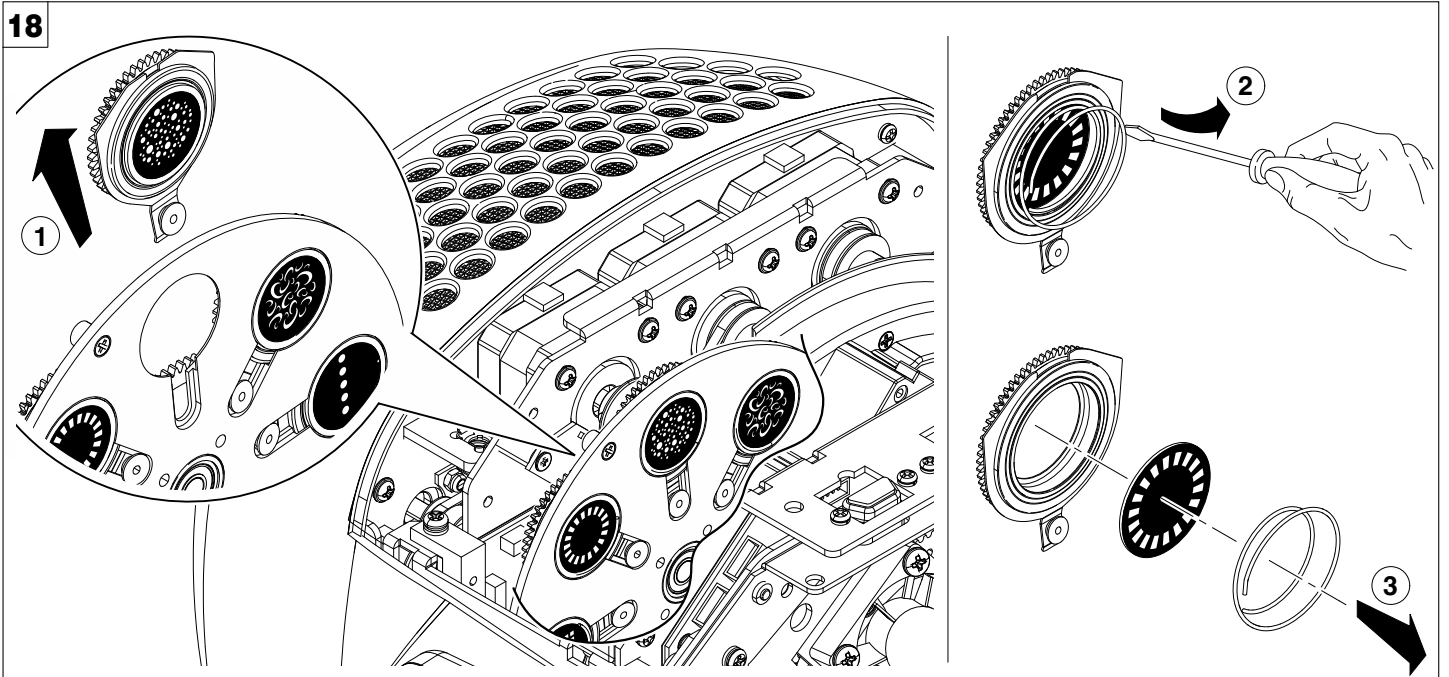

Bearing group replacement - Fig. 18

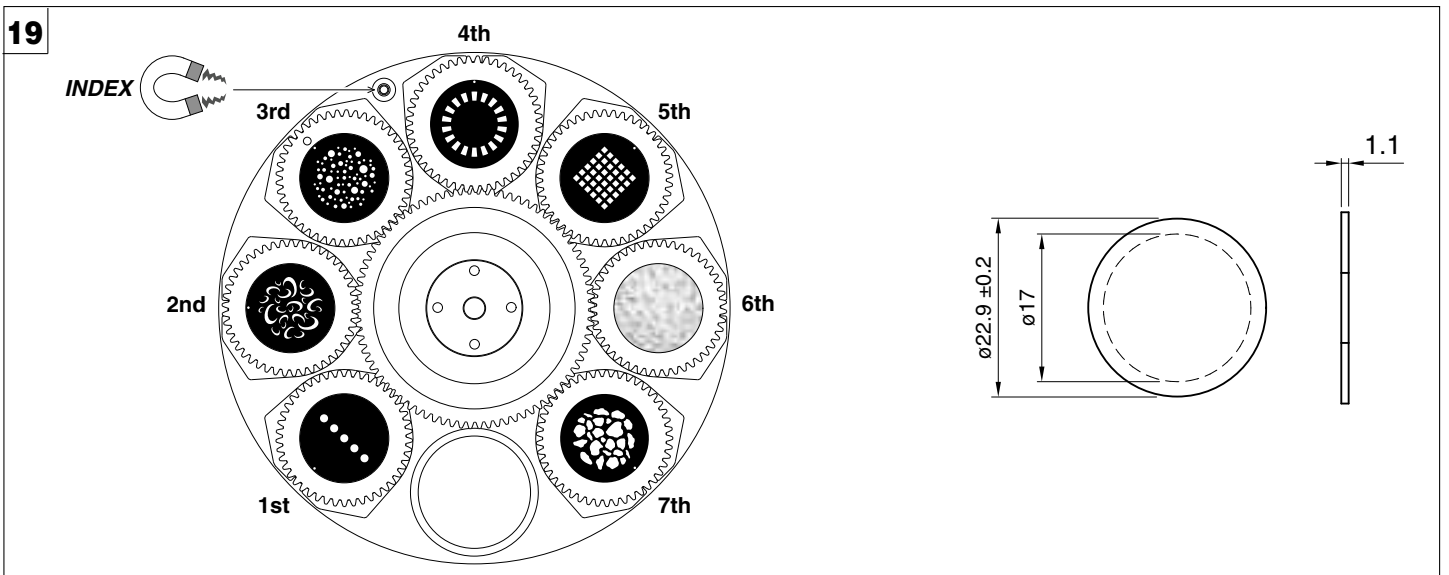

Replacing rotating gobos ($\phi 22.9$ mm – max 17 mm image – thickness 1.1 mm) - Fig. 19

- The rotating gobo wheel only use dichroic glass gobos (it is not possible to use metal gobos);
- For more information contact Claypaky;

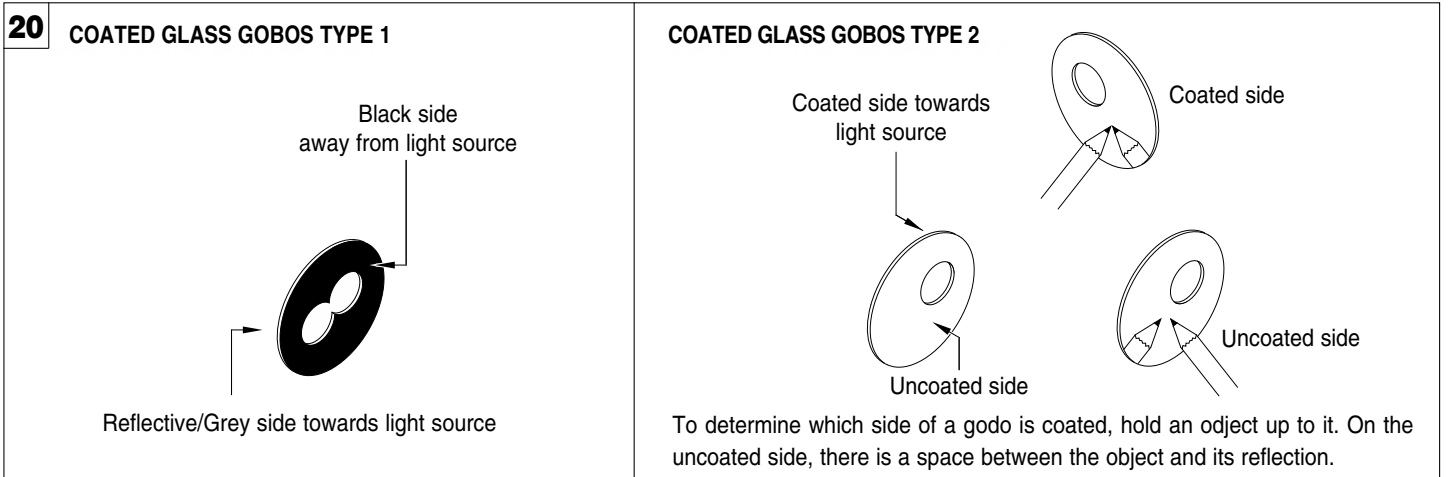

Gobo orientation - Fig. 20

The pictures shown the correct gobos orientation.

4.5 - Battery removal

21

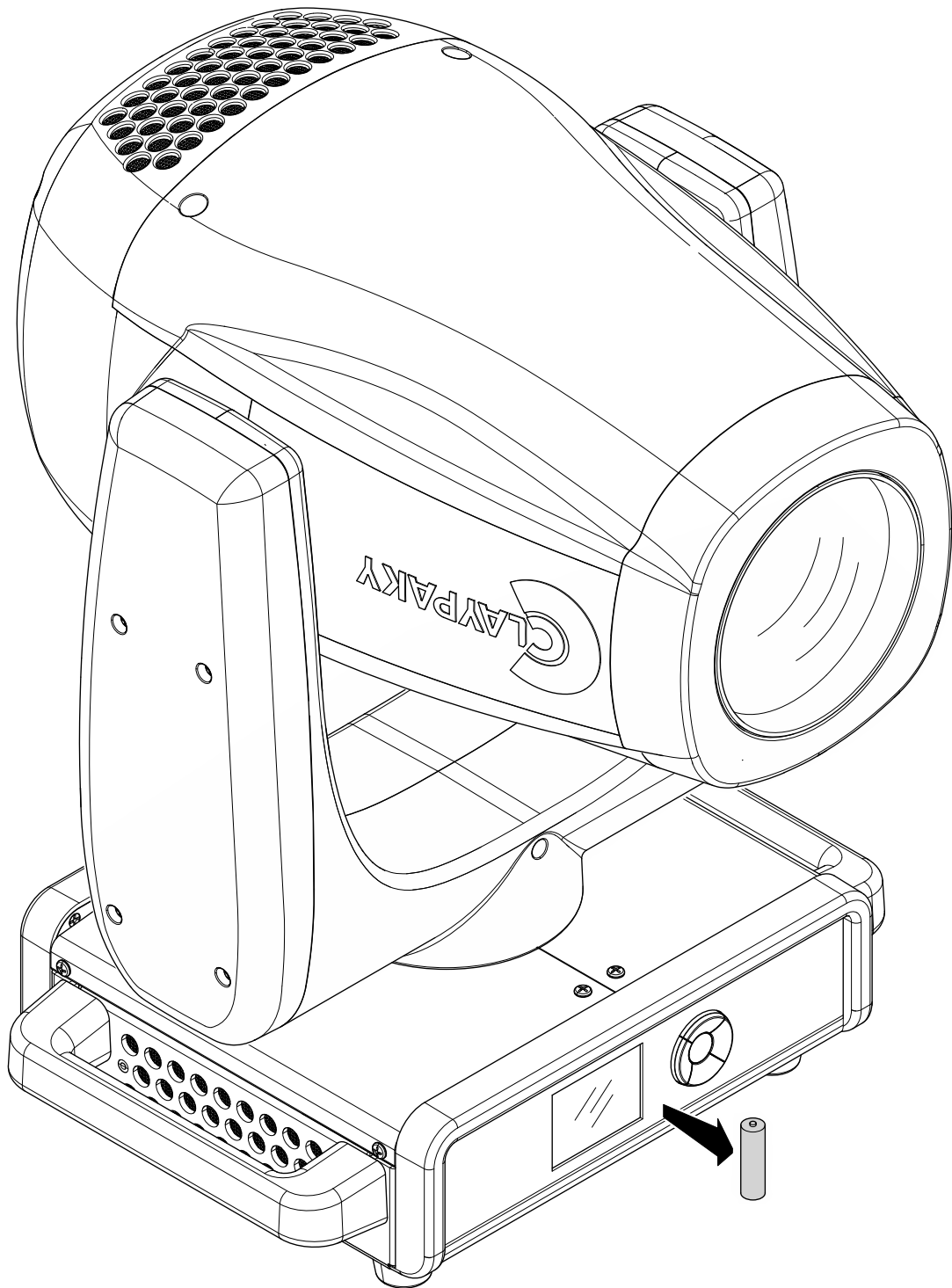

This product contains a rechargeable battery. To preserve the environment, please dispose the battery at the end of its life according to the regulation in force.

5. DIMENSIONS

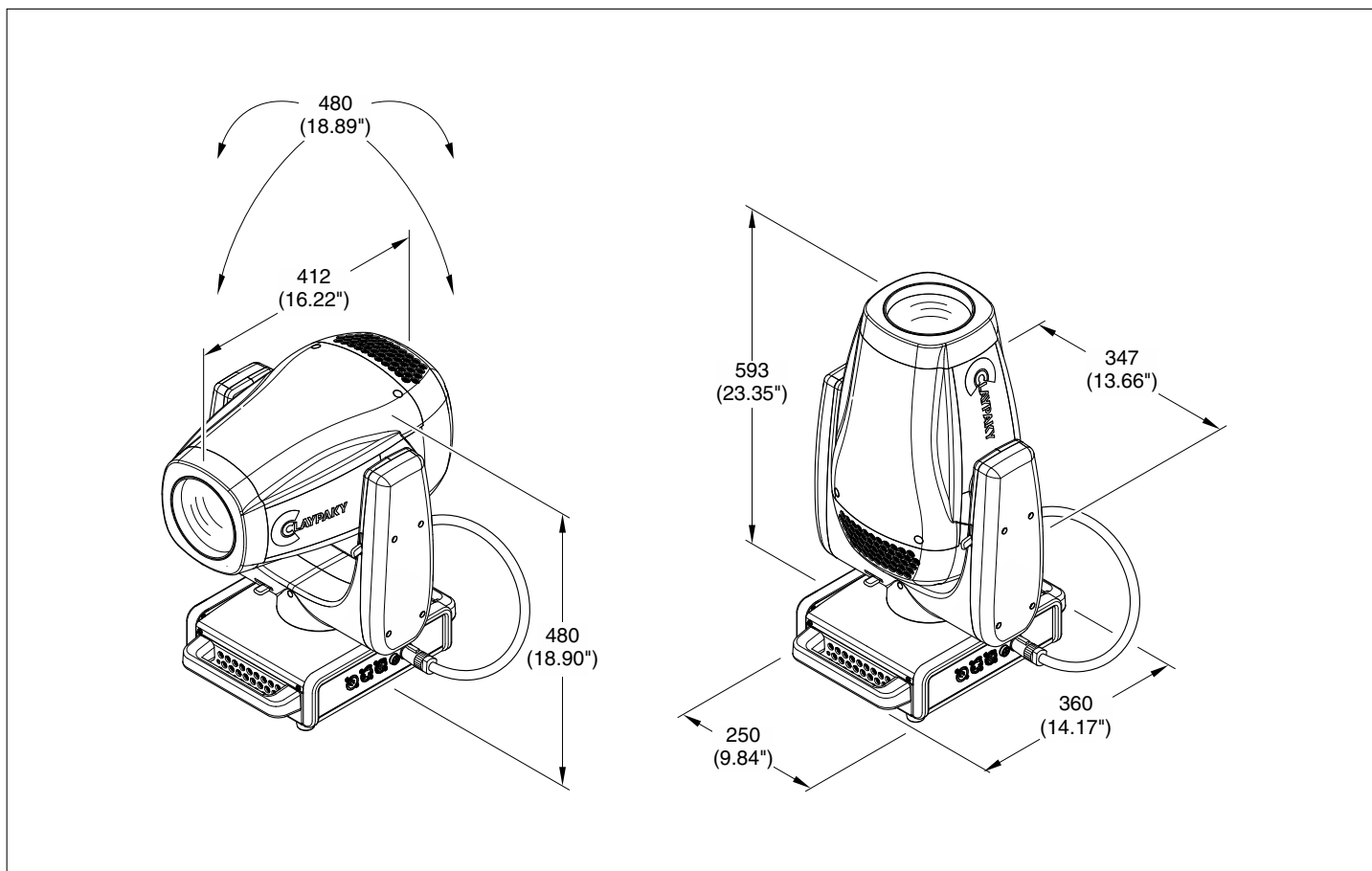

6. CAUSE AND SOLUTION OF PROBLEMS

THE PROJECTOR WILL NOT SWITCH ON			PROBLEMS
ELECTRONICS NON-OPERATIONAL			
DEFECTIVE PROJECTION			
REDUCED LUMINOSITY			
	POSSIBLE CAUSES	CHECKS AND REMEDIES	
●	No mains supply.	Check the power supply voltage.	
●	● Light source exhausted or defective.	Call an authorised technician.	
●	● Signal transmission cable faulty or disconnected.	Replace the cables.	
●	● Incorrect addressing.	Check addresses (see instructions).	
●	● Fault in the electronic circuits.	Call an authorised technician.	
●	● Lenses broken	Call an authorised technician.	
●	● ● Dust or grease deposited.	Clean (see instructions).	